

# MV-IDH2000B

## Wireless Handheld Code Reader



### Introduction

MV-IDH2000B wireless handheld code reader decodes different types of 1D and 2D codes rapidly. With the built-in intelligent code reading algorithm, it can easily decoding codes with spots, defects and low contrast ratio, and entry level DPM codes. With data cable, the code reader can realize charging function.

### Key Feature

- Built-in code reading algorithm for decoding different types of 1D codes and 2D codes.
- Provides good robustness to read codes with spots, defects and low contrast ratio.
- Supports continuous code reading, batch code reading for improving code reading efficiency.
- Supports wireless communication via Bluetooth.
- Adopts 2700 mAh battery with long standby time.
- IP42 and drop height of 1.8 m.

### Applicable Industry

Intelligent manufacturing, retail, logistics, medical treatment, enterprise and public institutions, etc.

### Available Model

- 0.3 MP, standard distance, with USB charging base set:  
MV-IDH2000B/03SR/03WN/UC
- 1.3 MP, standard distance, with USB charging base set:  
MV-IDH2000B/13SR/05WN/UC
- 1.3 MP, near distance, with USB charging base set:  
MV-IDH2000B/13NR/05WN/UC
- 0.3 MP, standard distance, handheld code reader only:  
MV-IDH2000B/03SR/03WN
- 1.3 MP, standard distance, handheld code reader only:  
MV-IDH2000B/13SR/05WN
- 1.3 MP, near distance, handheld code reader only:  
MV-IDH2000B/13NR/05WN

### Accessories

- Smart base: MV-IDH2000B/CBASE/U

## Specification

<b>Model</b>	<b>MV-IDH2000B/03SR/03WN</b> <b>MV-IDH2000B/03SR/03WN/UC</b>
<b>Performance</b>	
<b>Symbologies</b>	1D codes: Code 39, Code 93, Code 128, GS1-Code128, CodaBar, EAN 8, EAN 13, ISBN, ISSN, ITF 25, ITF 14, UPCA, UPCE
	2D codes: QR Code, Data Matrix, MicroQR, Aztec
	Stacked code: PDF417
<b>Min. accuracy</b>	4 mil
<b>Sensor type</b>	CMOS
<b>Resolution</b>	640 × 480
<b>Depth of field*</b>	EAN 13 (13 mil): 30 mm to 240 mm Code 39 (5 mil): 50 mm to 100 mm Code 128 (10 mil): 30 mm to 240 mm Data Matrix (10 mil): 40 mm to 130 mm QR Code (15 mil): 15 mm to 205 mm
<b>Field of view</b>	Horizontal 42°, vertical 32°
<b>Detection angle</b>	Tilt angle ± 60°, skew angle ± 60°, rotation angle 360°
<b>Symbol contrast</b>	20%
<b>Wireless communication</b>	
<b>Communication mode</b>	Bluetooth BT 5.1, BLE
<b>Wireless range</b>	80 m (open range)
<b>Communication protocol</b>	SmartSDK, Bluetooth, USB
<b>Electrical feature</b>	
<b>Data interface</b>	USB 2.0 (Type B)
<b>Battery</b>	2700 mAh
<b>Charging time</b>	6 h
<b>Endurance</b>	12 h (interval scanning, once in 2 seconds)
<b>Power supply</b>	5 VDC
<b>Current consumption</b>	1.5 A (max.), 0.14 A (during standby)
<b>Mechanical</b>	
<b>Focal length</b>	3.1 mm
<b>Ambient illumination</b>	0 lux to 100000 lux
<b>Light source</b>	White LED
<b>Aiming system</b>	Orange LED
<b>Prompt</b>	LED indicator, buzzer, vibrator
<b>Dimension</b>	66.5 mm × 94 mm × 169.5 mm (2.6" × 3.7" × 6.7")
<b>Weight</b>	Approx. 160 g (0.4 lb.)
<b>Ingress protection</b>	IP42
<b>Temperature</b>	Working temperature: -10 °C to 50 °C (14 °F to 122 °F) Storage temperature: -20 °C to 60 °C (-4 °F to 140 °F) Charging temperature: 0 °C to 40 °C (32 °F to 104 °F)
<b>Humidity</b>	5% RH to 95% RH (no condensation)
<b>Drop height</b>	1.8 m
<b>General</b>	
<b>Client software</b>	IDMVS
<b>Certification</b>	CE, KC

\*Test condition: Environment temperature=25 °C (77 °F), ambient illumination=250 lux filament lamp, Hikrobot's test symbologies are used.

**Specification**

Model	MV-IDH2000B/13NR/05WN MV-IDH2000B/13NR/05WN/UC	MV-IDH2000B/13SR/05WN MV-IDH2000B/13SR/05WN/UC
<b>Performance</b>		
<b>Symbologies</b>	1D codes: Code 39, Code 93, Code 128, GS1-Code128, CodaBar, EAN 8, EAN 13, ISBN, ISSN, ITF 25, ITF 14, UPCA, UPCE	
	2D codes: QR Code, Data Matrix, MicroQR, Aztec	
	Stacked code: PDF417	
<b>Min. accuracy</b>	1D codes: 3 mil 2D codes: 4 mil	1D codes: 3 mil 2D codes: 5 mil
<b>Sensor type</b>	CMOS	
<b>Resolution</b>	1280 × 1024	
<b>Depth of field*</b>	Code 128 (3 mil): 30 mm to 110 mm Code 128 (10 mil): 20 mm to 205 mm Data Matrix (5 mil): 40 mm to 85 mm QR Code (10 mil): 20 mm to 140 mm QR Code (20 mil): 20 mm to 200 mm	Code 128 (3 mil): 70 mm to 160 mm Code 128 (10 mil): 30 mm to 440 mm QR Code (10 mil): 45 mm to 235 mm QR Code (15 mil): 20 mm to 360 mm QR Code (20 mil): 20 mm to 460 mm
<b>Field of view</b>	Horizontal 39°, vertical 29°	
<b>Detection angle</b>	Tilt angle ± 60°, skew angle ± 60°, rotation angle 360°	
<b>Symbol contrast</b>	20%	
<b>Wireless communication</b>		
<b>Communication mode</b>	Bluetooth BT 5.1, BLE	
<b>Wireless range</b>	80 m (open range)	
<b>Communication protocol</b>	SmartSDK, Bluetooth, USB	
<b>Electrical feature</b>		
<b>Data interface</b>	USB 2.0 (Type B)	
<b>Battery</b>	2700 mAh	
<b>Charging time</b>	6 h	
<b>Endurance</b>	12 h (interval scanning, once in 2 seconds)	
<b>Power supply</b>	5 VDC	
<b>Current consumption</b>	1.5 A (max.), 0.14 A (during standby)	
<b>Mechanical</b>		
<b>Focal length</b>	4.9 mm	
<b>Ambient illumination</b>	0 lux to 100000 lux	
<b>Light source</b>	White LED	
<b>Aiming system</b>	Cross laser aiming	
<b>Prompt</b>	LED indicator, buzzer, vibrator	
<b>Dimension</b>	66.5 mm × 94 mm × 169.5 mm (2.6" × 3.7" × 6.7")	
<b>Weight</b>	Approx. 160 g (0.4 lb.)	
<b>Ingress protection</b>	IP42	
<b>Temperature</b>	Working temperature: -10 °C to 50 °C (14 °F to 122 °F) Storage temperature: -20 °C to 60 °C (-4 °F to 140 °F) Charging temperature: 0 °C to 40 °C (32 °F to 104 °F)	
<b>Humidity</b>	5% RH to 95% RH (no condensation)	
<b>Drop height</b>	1.8 m	

## Specification

**HIKROBOT**

General	
Client software	IDMVS
Certification	CE, KC

\*Test condition: Environment temperature=25 °C (77 °F), ambient illumination=250 lux filament lamp, Hikrobot's test symbologies are used.

Laser Information of IDH 2000B Series Product	
Laser safety class	Laser 2
Wavelength	650 nm
Pulse width	8 ms
Maximum power	1 mW

## Specification (Smart Base)

Model	MV-IDH2000B/CBASE/U
Electrical feature	
Data interface	USB 2.0 (Type B), USB 2.0 (Type A)
Power supply	5 VDC
Current consumption	1.5 A (max.), 0.01 A (during standby)
Mechanical	
Dimension	82.6 mm × 121.8 mm × 76.1 mm (3.3" × 4.8" × 3.0")
Weight	Approx. 120 g (0.3 lb.)
Ingress protection	IP40
Temperature	Working temperature: -10 °C to 50 °C (14 °F to 122 °F) Storage temperature: -20 °C to 60 °C (-4 °F to 140 °F)
Humidity	5% RH to 95% RH (no condensation)

## Dimension

Code reader:

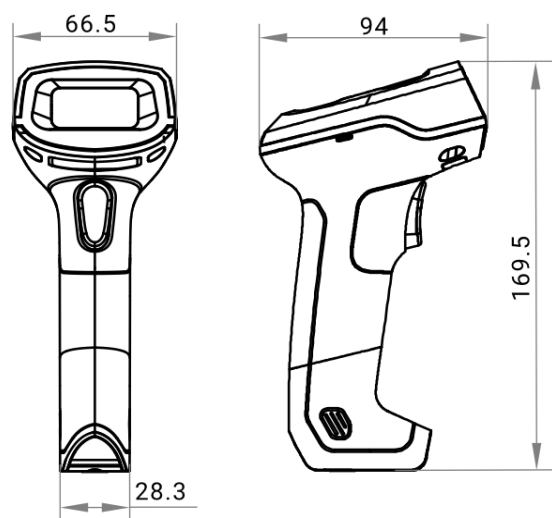

Unit: mm

Smart base:

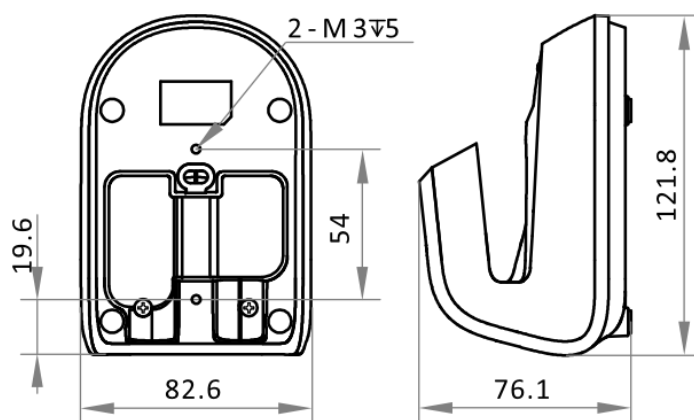

Unit: mm